



ATTENTION
OBSERVE PRECAUTIONS
FOR HANDLING
ELECTROSTATIC
DISCHARGE
SENSITIVE

Features

- Single color.
- Suitable for all SMT assembly and solder process.
- Available on tape and reel.
- Ideal for backlighting.
- White SMD package, silicone resin.
- Low thermal resistance.
- Package: 1500pcs / reel.
- Moisture sensitivity level : level 2a.
- RoHS compliant.



Package Dimensions

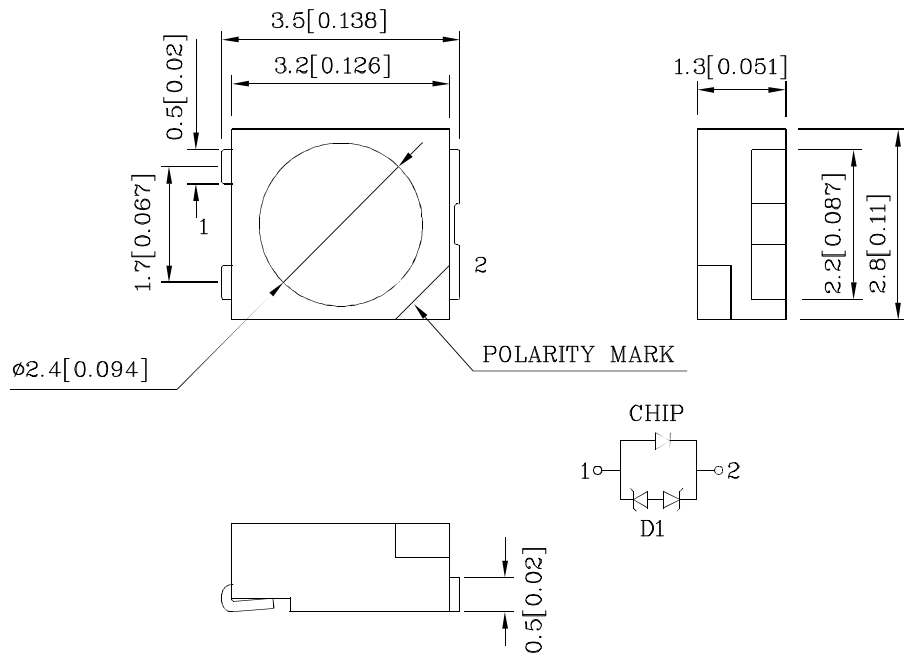

Notes:

1. All dimensions are in millimeters (inches).
2. Tolerance is $\pm 0.25(0.01)$ unless otherwise noted.
3. Specifications are subject to change without notice.

Handling Precautions

Compare to epoxy encapsulant that is hard and brittle, silicone is softer and flexible. Although its characteristic significantly reduces thermal stress, it is more susceptible to damage by external mechanical force.

As a result, special handling precautions need to be observed during assembly using silicone encapsulated LED products. Failure to comply might leads to damage and premature failure of the LED.

1. Handle the component along the side surfaces by using forceps or appropriate tools.

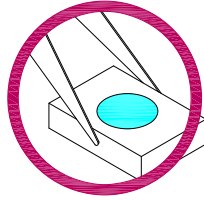

2. Do not directly touch or handle the silicone lens surface. It may damage the internal circuitry.

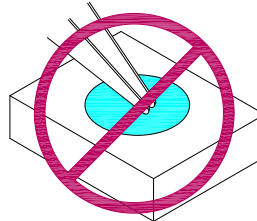
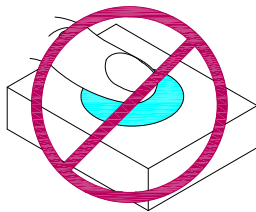

3. Do not stack together assembled PCBs containing exposed LEDs. Impact may scratch the silicone lens or damage the internal circuitry.

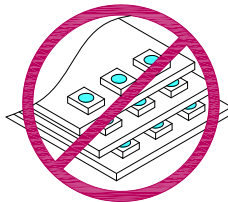

4. The outer diameter of the SMD pickup nozzle should not exceed the size of the LED to prevent air leaks. The inner diameter of the nozzle should be as large as possible.
5. A pliable material is suggested for the nozzle tip to avoid scratching or damaging the LED surface during pickup.
6. The dimensions of the component must be accurately programmed in the pick-and-place machine to insure precise pickup and avoid damage during production.

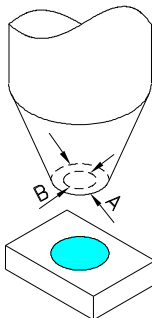

Part Number	Emitting Color	Emitting Material	Lens-color	Luminous Intensity (IF=150mA) mcd		Luminous Flux (IF=150mA) mlm		Viewing Angle 2 θ 1/2 [2]
				min.	typ.	min.	typ.	
XZWR25X109SWB	Warm White	InGaN	Water Clear	4700	8000	20000	29000	120°

Absolute Maximum Ratings at TA=25°C

Parameter	Symbol	Value	Unit
Power Dissipation	PD	600	mW
Junction Temperature [1]	TJ	110	°C
Reverse Voltage	VR	5	V
Operating Temperature	Top	-40 To +85	°C
Storage Temperature	Tstg	-40 To +85	°C
DC Forward Current [1]	IF	150	mA
Peak Forward Current [2]	IFM	300	mA
Thermal Resistance [1] (Junction/ambient)	Rth j-a	180	°C/W
Thermal Resistance [1] (Junction/solder point)	Rth j-S	60	°C/W
Electrostatic Discharge Threshold (HBM)		8000	V

Notes:

- Results from mounting on PC board FR4(pad size ≥ 70mm²), mounted on pc board-metal core PCB is recommend for lowest thermal Resistance.
- 2.0 1/2 is the angle from optical centerline where the luminous intensity is 1/2 of the optical peak value.
- 3.1/10 Duty Cycle, 0.1ms Pulse Width.

Electrical / Optical Characteristics at TA=25°C

Parameter	Symbol	Value	Unit
Forward Voltage IF=150mA [Min.]	VF	2.7	V
Forward Voltage IF=150mA [Typ.]		3.5	
Forward Voltage IF=150mA [Max.]		4.0	
Reverse Current (VR = 5V) [Max.]	IR	10	uA
Color Temperature IF=150mA [Min.]	CCT	2870	K
Color Temperature IF=150mA [Typ.]		3000	
Color Temperature IF=150mA [Max.]		3220	
Temperature Coefficient Of x IF=150mA, -10 ° C ≤ T ≤ 100 ° C [Typ.]	TCx	-0.15	10 ⁻³ /° C
Temperature Coefficient Of y IF=150mA, -10 ° C ≤ T ≤ 100 ° C [Typ.]	TCy	-0.13	10 ⁻³ /° C
Temperature Coefficient Of VF IF=150mA, -10 ° C ≤ T ≤ 100 ° C [Typ.]	TCv	-3.1	mV/° C

XZWR25X109SWB

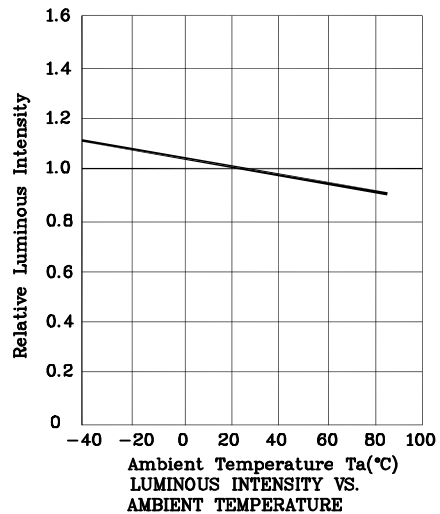
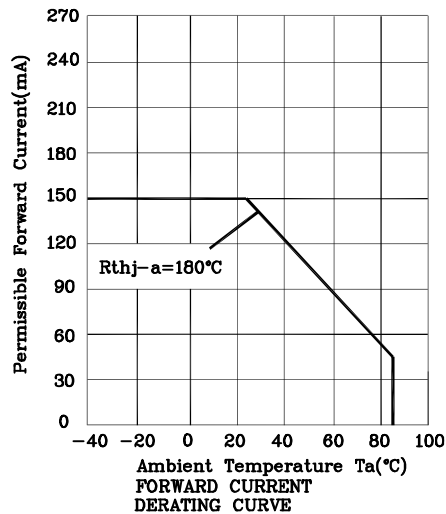
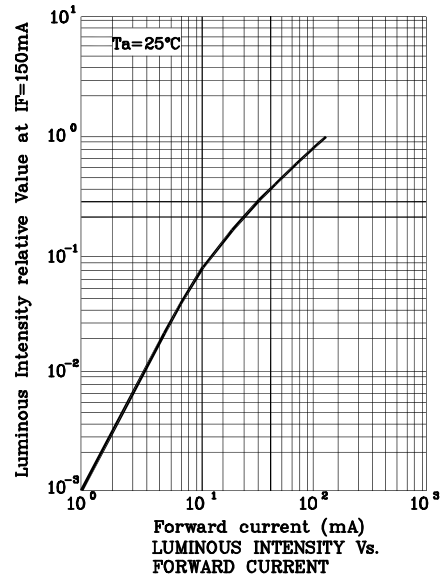
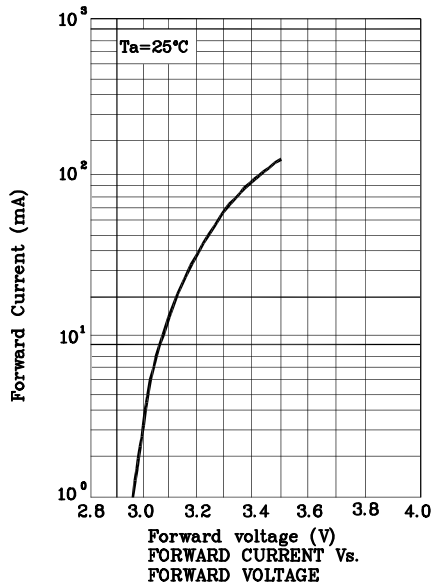
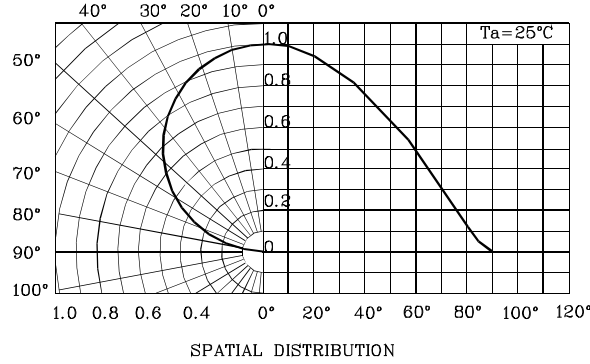

CCT 2500-7000 K Bin Code

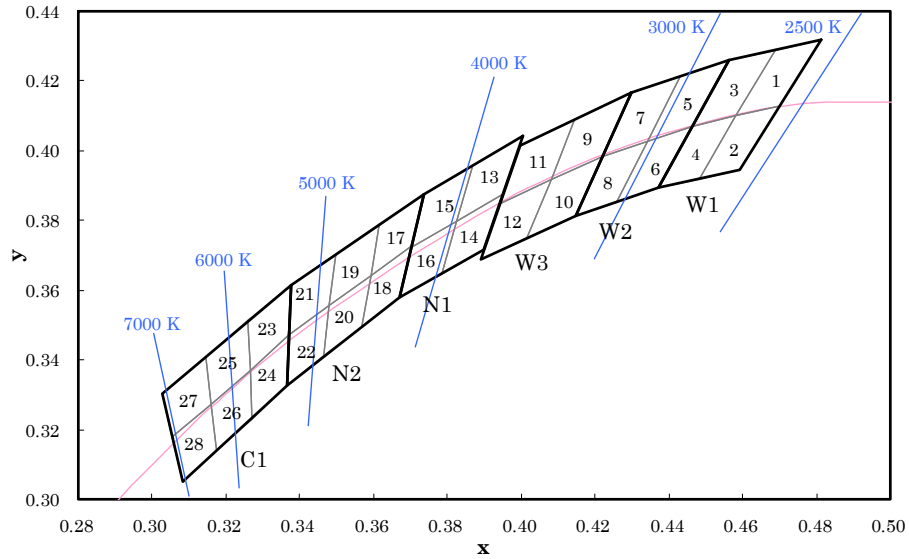

Color	Group	Chromaticity Regions	CCT (K)		
			Min.	Typ.	Max.
Warm White	W1	1, 2, 3, 4	2580	2700	2870
	W2	5, 6, 7, 8	2870	3000	3220
	W3	9, 10, 11, 12	3220	3500	3710
Neutral White	N1	13, 14, 15, 16	3710	4000	4260
	N2	17, 18, 19, 20, 21, 22	4260	4700	5310
Cool White	C1	23, 24, 25, 26, 27, 28	5310	6000	7040

Notes:
Shipment may contain more than one chromaticity regions. Orders for single chromaticity region are generally not accepted.
Measurement tolerance of the chromaticity coordinates is ± 0.01 .

	x	y	x	y	x	y	x	y			
1	0.4582	0.4099	8	0.4147	0.3814	15	0.3702	0.3722	22	0.3481	0.3557
	0.4687	0.4289		0.4221	0.3984		0.3736	0.3874		0.3370	0.3472
	0.4813	0.4319		0.4342	0.4028		0.3869	0.3958		0.3364	0.3328
	0.4700	0.4126		0.4259	0.3853		0.3825	0.3798		0.3466	0.3411
2	0.4483	0.3919	9	0.4080	0.3916	16	0.3670	0.3578	23	0.3376	0.3616
	0.4582	0.4099		0.4146	0.4089		0.3702	0.3722		0.3260	0.3512
	0.4700	0.4126		0.4299	0.4165		0.3825	0.3798		0.3265	0.3371
	0.4593	0.3944		0.4221	0.3984		0.3783	0.3646		0.3370	0.3472
3	0.4465	0.4071	10	0.4017	0.3751	17	0.3736	0.3874	24	0.3370	0.3472
	0.4562	0.4260		0.4080	0.3916		0.3616	0.3788		0.3265	0.3371
	0.4687	0.4289		0.4221	0.3984		0.3592	0.3641		0.3270	0.3230
	0.4582	0.4099		0.4147	0.3814		0.3703	0.3726		0.3364	0.3328
4	0.4373	0.3893	11	0.3941	0.3848	18	0.3703	0.3726	25	0.3260	0.3512
	0.4465	0.4071		0.3996	0.4015		0.3592	0.3641		0.3144	0.3408
	0.4582	0.4099		0.4146	0.4089		0.3568	0.3495		0.3160	0.3274
	0.4483	0.3919		0.4080	0.3916		0.3670	0.3578		0.3265	0.3371
5	0.4342	0.4028	12	0.3889	0.3690	19	0.3616	0.3788	26	0.3265	0.3371
	0.4430	0.4212		0.3941	0.3848		0.3496	0.3702		0.3160	0.3274
	0.4562	0.4260		0.4080	0.3916		0.3481	0.3557		0.3175	0.3139
	0.4465	0.4071		0.4017	0.3751		0.3592	0.3641		0.3270	0.3230
6	0.4259	0.3853	13	0.3825	0.3798	20	0.3592	0.3641	27	0.3144	0.3408
	0.4342	0.4028		0.3869	0.3958		0.3481	0.3557		0.3028	0.3304
	0.4465	0.4071		0.4006	0.4044		0.3466	0.3411		0.3055	0.3177
	0.4373	0.3893		0.3950	0.3875		0.3568	0.3495		0.3160	0.3274
7	0.4221	0.3984	14	0.3783	0.3646	21	0.3496	0.3702	28	0.3160	0.3274
	0.4299	0.4165		0.3825	0.3798		0.3376	0.3616		0.3055	0.3177
	0.4430	0.4212		0.3950	0.3875		0.3370	0.3472		0.3081	0.3049
	0.4342	0.4028		0.3898	0.3716		0.3481	0.3557		0.3175	0.3139

Reflow soldering is recommended and the soldering profile is shown below.
Other soldering methods are not recommended as they might cause damage to the product.

Reflow Soldering Profile For Lead-free SMT Process.

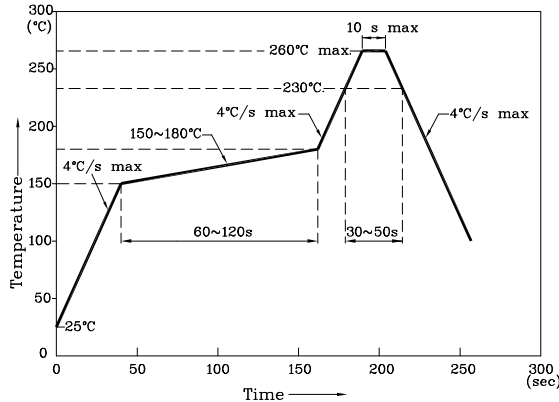



NOTES:

1. Maximum soldering temperature should not exceed 260°C.
2. Recommended reflow temperature: 145°C-260°C.
3. Do not put stress to the epoxy resin during high temperatures conditions.

❖ **Recommended Soldering Pattern**
 (Units : mm; Tolerance: ±0.1)

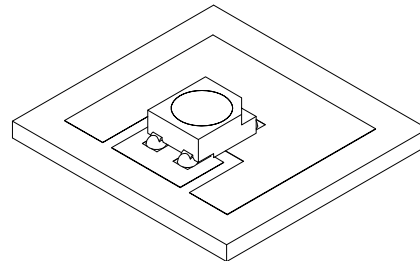
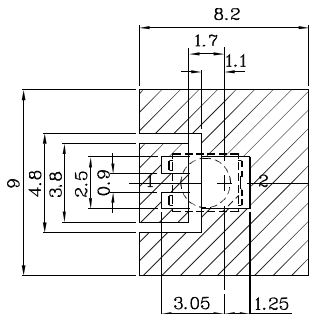
❖ **The device has a single mounting surface. The device must be mounted according to the specifications.**



 Solder resist

❖ **Tape Specification (Units : mm)**

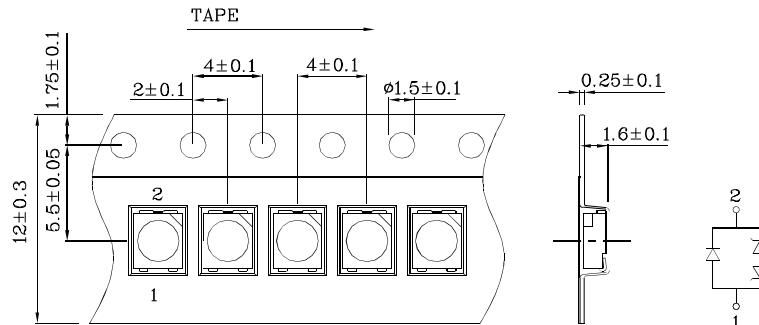

Remarks:

If special sorting is required (e.g. binning based on forward voltage, Luminous intensity / luminous flux)



the typical accuracy of the sorting process is as follows:



1. Luminous intensity / luminous flux: +/-15%
2. Forward Voltage: +/-0.1V

Note: Accuracy may depend on the sorting parameters.

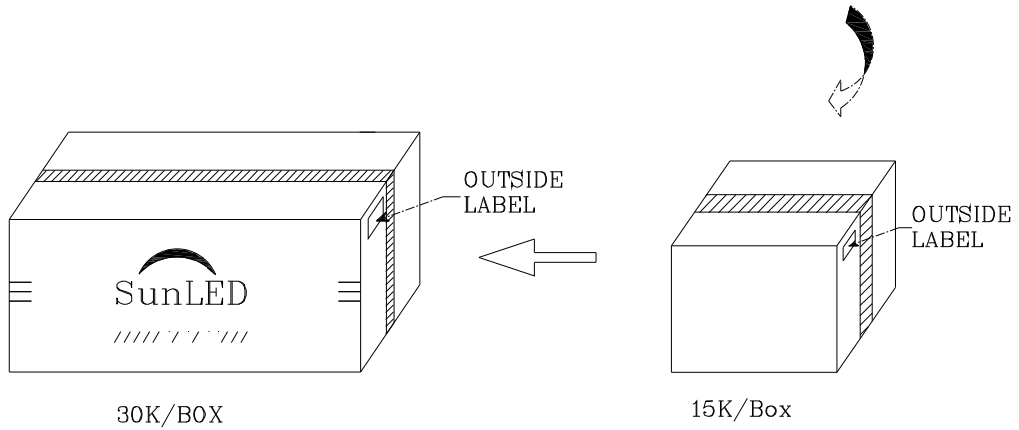
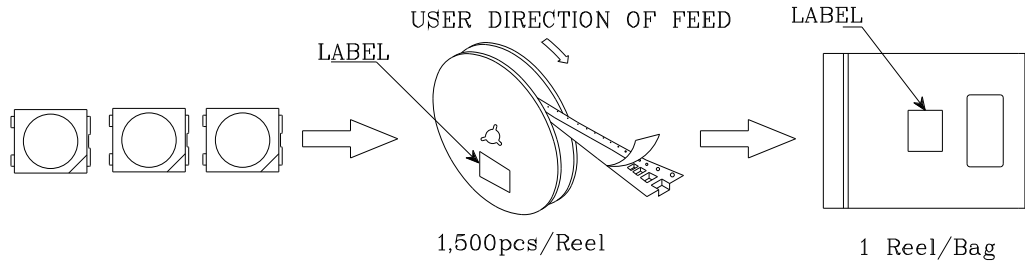
PACKING & LABEL SPECIFICATIONS

XZWR25X109SWB

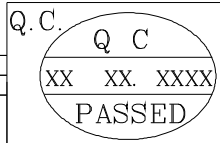
	
P/N0 : XZxxx109x	FQC
QTY : 1,500 pcs	CODE: XXX
S/N : XX	
LOT NO :	
	
XXXXXXXXXXXXXXXXXXXXXXXXXXXX	
RoHS Compliant	