

PRELIMINARY SPEC



**ATTENTION**  
 OBSERVE PRECAUTIONS  
 FOR HANDLING  
 ELECTROSTATIC  
 DISCHARGE  
 SENSITIVE  
 DEVICES

**Features**

- HIGH VISIBILITY.
- WATER PROOF PACKAGE WITH HOOD SUITABLE FOR OUTDOOR AND INDOOR INFORMATION BOARDS.
- CAN PRODUCE ANY COLOR IN VISIBLE SPECTRUM, INCLUDING WHITE LIGHT.
- RoHS COMPLIANT.

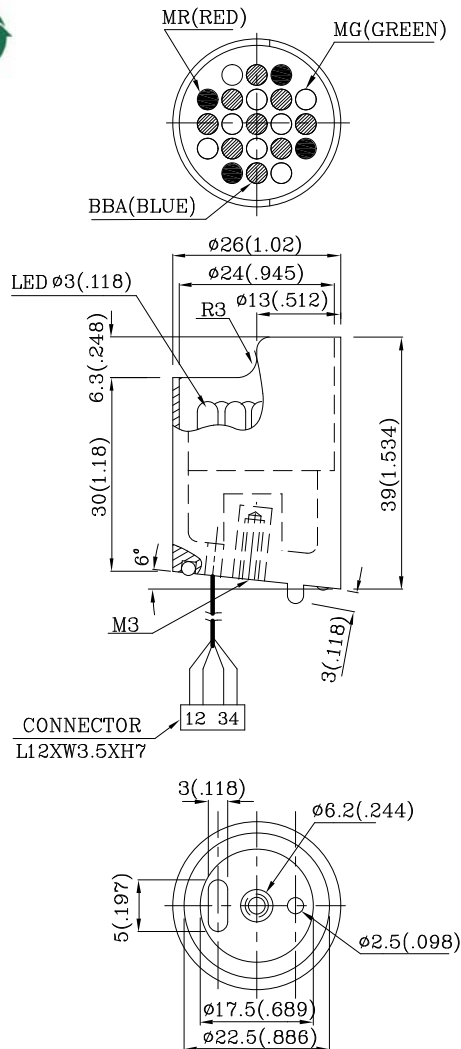

XLMR32W-10.5x4PCS  
 XLBBA32W-10.5x9PCS  
 XLMG32W-10.5x8PCS

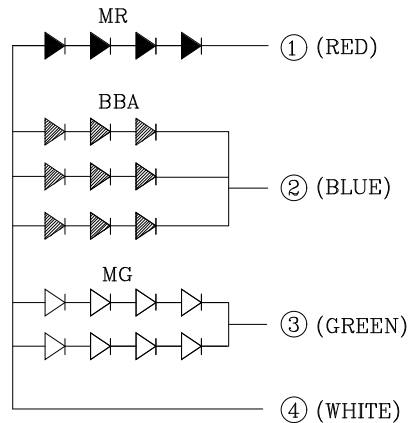

Notes:

1. All dimensions are in millimeters (inches).
2. Tolerance is  $\pm 0.25(0.01)$  unless otherwise noted.
3. Specifications are subject to change without notice.

**Electrical / Optical Characteristics at TA=25°C**

Symbol	Parameter	Device	Wafer	Min.	Typ.	Max.	Units	Test Conditions	
Iv	Luminous Intensity	XK4MR9BBA8MGW87	MR BBA MG	650 2800 480	1790 4490 1195	-	mcd	If=20mA If=60mA If=40mA	
2 01/2	Viewing Angle		MR BBA MG	-	40	-	deg	-	
VF	Forward Voltage		MR BBA MG	-	7.4 9.6 8.8	10 12 10	V	If=20mA If=60mA If=40mA	
λ P	Peak Wavelength		MR BBA MG	-	660 468 565	-	nm	If=20mA If=60mA If=40mA	
λ D	Dominate Wavelength		MR BBA MG	-	640 470 568	-	nm	If=20mA If=60mA If=40mA	
Δλ 1/2	Spectral Line Half-width		MR BBA MG	-	20 21 30	-	nm	If=20mA If=60mA If=40mA	
IR	Reverse Current				-	-	60	uA	VR = 5V

**Absolute Maximum Ratings at TA=25°C**

Parameter	Type	Units	
Total Power dissipation	MR	1650	mW
	BBA		
	MG		
DC Forward Current	MR	25	mA
	BBA	75	
	MG	50	
Reverse Voltage	5	V	
Operating Temperature	-40 To +70	°C	
Storage Temperature	-40 To +85	°C	

**PACKING & LABEL SPECIFICATIONS**

**XK4MR9BBA8MGW87**

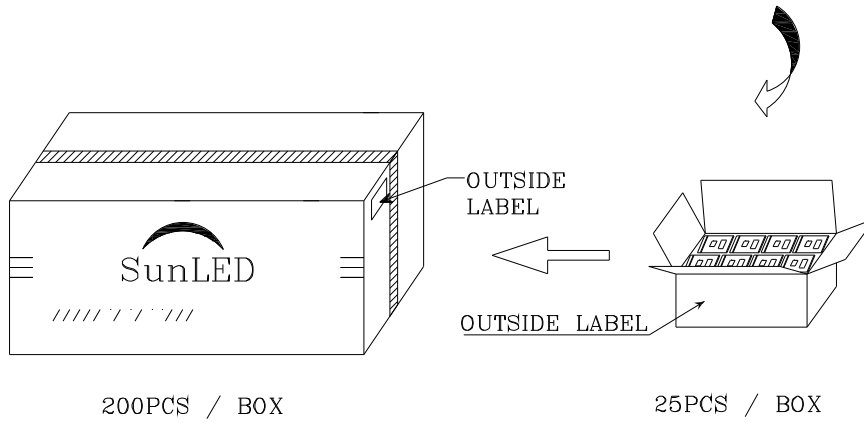
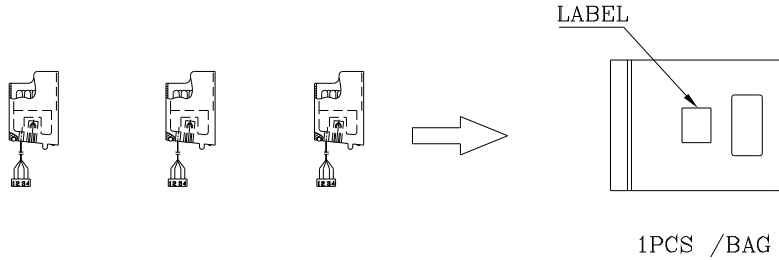

P/NO : XKxxx	
QTY : 1 pcs	CODE: XXX
S/N : XX	
LOT NO:	
 xxxxxxxxxxxxxxxxxxxxxxxx	
RoHS Compliant	